



50Ω TERMINATED 40 GHz SMA 2.9 N/O S.P.6 T. SWITCH

OPTIONS: SUPP. DIODES

R F CHARACTERISTICS

NUMBER OF WAYS : 6
 FREQUENCY RANGE : 0 - 40 GHz
 IMPEDANCE : 50 Ohms

FREQUENCY (GHz)	0 - 6	6 -12.4	12.4- 18	18 -26.5	26.5- 40
V.S.W.R <=	1.30	1.40	1.50	1.70	2.00
INSERT. LOSS <=	0.20 dB	0.40 dB	0.50 dB	0.70 dB	0.90 dB
ISOLATION >=	70 dB	60 dB	60 dB	55 dB	50 dB
AVER. POWER (*)	40 W	25 W	15 W	10 W	3 W

TERMINATION IMPEDANCE : 50 Ohms
 TERMINATION AVG. POWER AT 25° C : 1 W per termination
 3 W total power

ELECTRICAL CHARACTERISTICS

ACTUATOR : NORMALLY OPEN
 NOMINAL CURRENT AT 25° C (*10%) : 250 mA
 ACTUATOR VOLTAGE (Vcc) : 12V (10.2 to 13V) / POSITIVE COMMON
 TERMINALS : Solder pins (250° max./30 sec.)

MECHANICAL CHARACTERISTICS

CONNECTORS : SMA 2.9 female per MIL-C 39012
 LIFE : 2.000.000 cycles per position
 SWITCHING TIME (nominal voltage;25° C) : < 15 ms
 CONSTRUCTION : splashproof
 WEIGHT : < 250 g

ENVIRONMENTAL CHARACTERISTICS

OPERATING TEMPERATURE RANGE (°C) : -25 , +75
 STORAGE TEMPERATURE RANGE (°C) : -55 , +85

(* : average power at 25° C per RF path)

This information is given as an indication. In the continual goal to improve our products, we reserve the right to make any modifications judged necessary

4113-9212 This information is given as an indication. In the continual goal to improve our products, we reserve the right to make any modifications judged necessary

R574802600

DRAWING

General tolerance: ± 0,5 mm

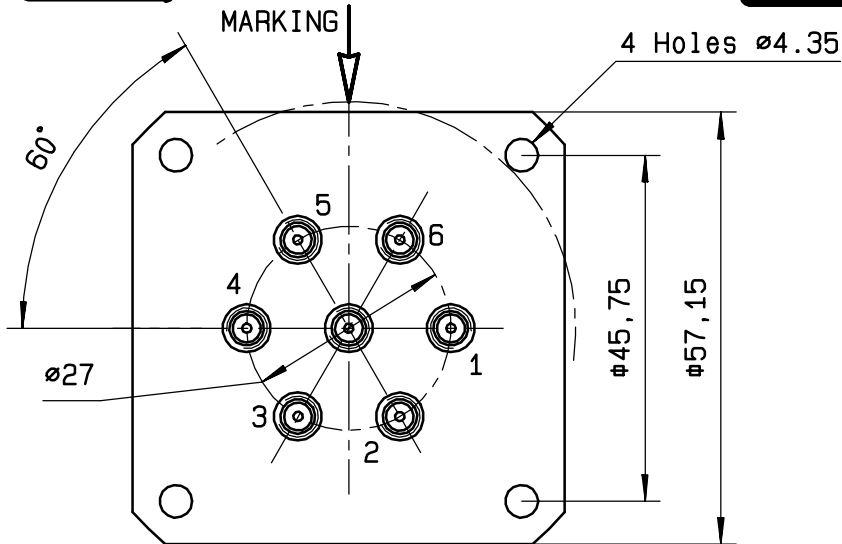

Voltage	RF continuity
-C +1	IN ↔ 1
-C +2	IN ↔ 2
-C +3	IN ↔ 3
-C +4	IN ↔ 4
-C +5	IN ↔ 5
-C +6	IN ↔ 6

TERMINALS

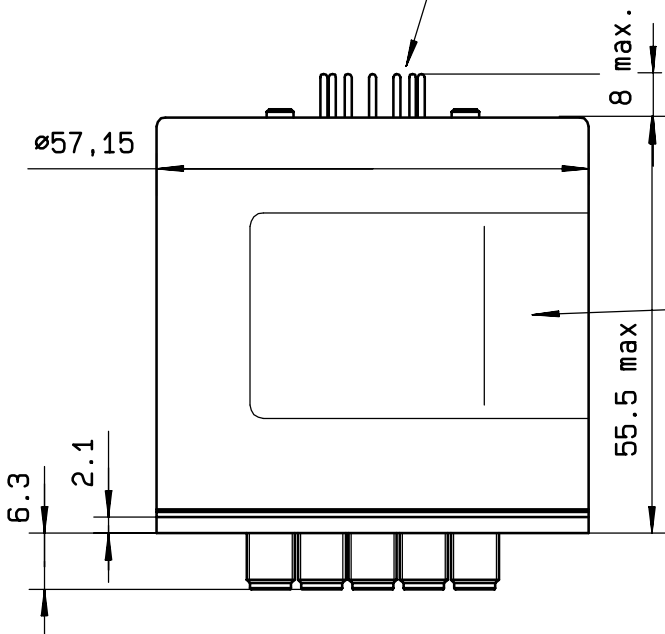

MARKING

TOP VIEW (TERMINALS)

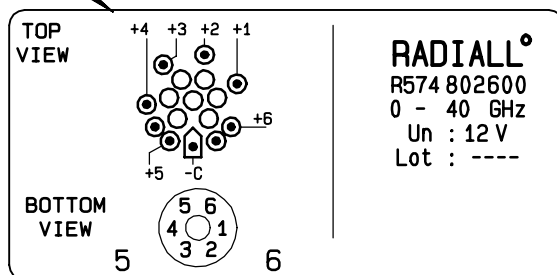

SCHEMATIC DIAGRAM

